

No.	NAME OF PART	Q'TY	M T L	REMARKS
1	Body	1	ADC12	
2	Driving unit cover	1	ADC12	
3	Apertometer 0~90° 10div.	1	GLASS	
4	Electric unit cover	1	ADC12	
5	Control unit cover	1	ADC12	
6	Wiring hole	2	-	NPT1/2
7	Manual handle shaft	1	S45C	
8	Output shaft	1	SUS304	
9	Stopper	1	ZnDC	
10	Stopper bolt/nut	2	SUS304	
11	Manual handle shaft rubber cap	1	NBR	

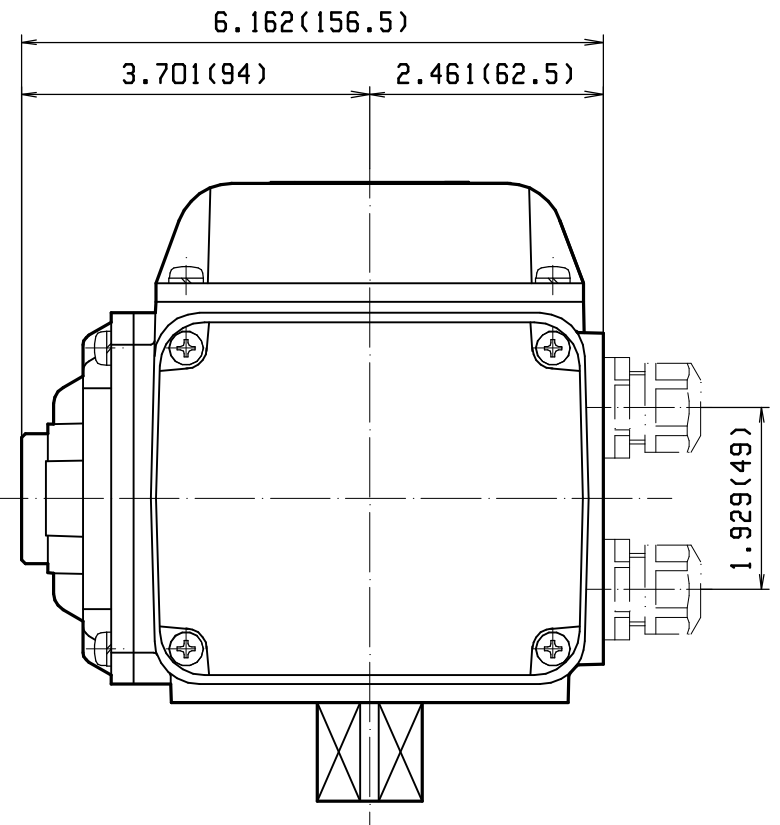
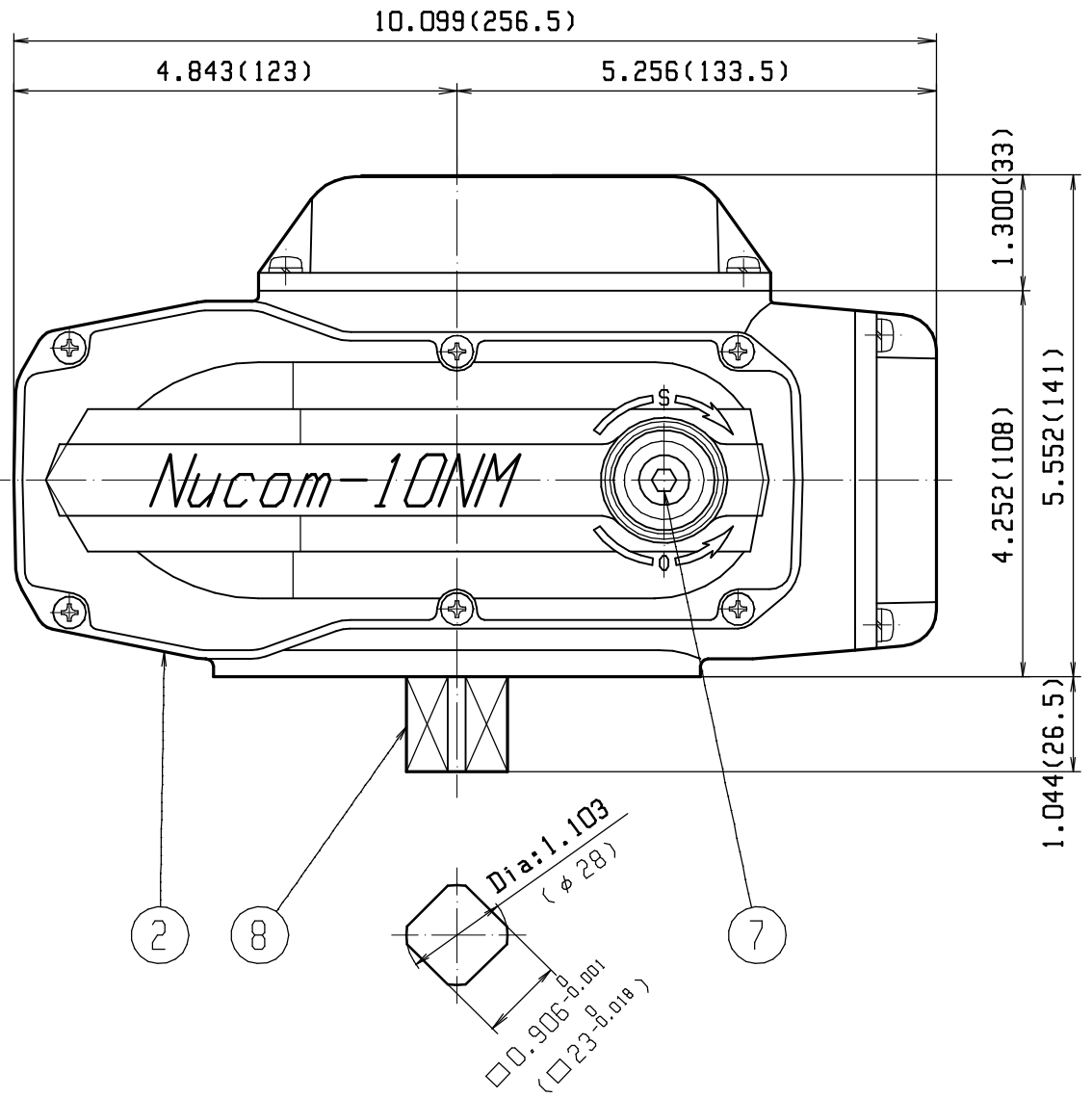

OUTPUT SHAFT POSITION : 0 %
DIMENSIONS ARE INCH(mm)

CERTIFICATE OF COMPLIANCE		
TYPE	CERTIFICATE NUMBER	ISSUED BY
NEMA-4,4X	161097-E177862	UL
CSA.NRTL/C	LR110832-1,2	CSA
CE	EMS 1B0704-1,2	ASSESSMENT SERVICE

DRIVING UNIT SPECIFICATION	
POWER SOURCE	AC115V · 120V · 240V 60Hz Single phase
CONTROL ANGLE	0~90° degree.
OPERATION SPEED	13sec./90deg.
OUTPUT SHAFT TORQUE	1763in-lb (196.13N · m)
MANUAL OPERATION	Available
INPUT SIGNAL	4~20mA · DC
RESOLUTION	Over 1/250
BODY MATERIAL	Aluminium diecast
COATING COLOR	Gray(N-6)
BODY WEIGHT	8.2 kg

NAME: ACTUATOR OUTER DIMENSIONS	APRV.	DATE	SIGN
MODEL: Nucom-10NM	CONF.		
	DRAW.	23, JAN, '02	K. SUGIYAMA
KOEI INDUSTRY CO., LTD.	DR. No,	24010GE1	